

Product information

S7-Panel-PLC

PC717T



(Figure contains optional periphery modules)



(valid from PLC-version PLC717T-xxx-**02**)

Changes to older versions of this document

Rev. 01 → **02**: new images, new design line, connectors added, drill jig info added

Rev. 02 → **03**: Information for disposal of old equipment

Description

S7-Panel-PLC with

- 7 TFT display (800x480 pixel)
- resistive touch (front protection class IP65)

Standard configuration:

RS232 with

- free ASCII protocol

RS485 with

- free ASCII protocol
- Modbus RTU
- with switchable terminate resistors for RS485

2x Ethernet (as switch or separated) with

- S7-connection (Put/Get)
- Send/ Receive via TCP and UDP,
- Modbus TCP

CAN

- protocol compatible to
 - CANopen®
 - Layer2 communication
- with switchable terminate resistors for RS485

Micro-SD-card slot

- for SD-cards up to 8GByte

Run/Stop switch

State LEDs for

Power, Battery, Error, Run

Inserting stripes

- for Logo and identification (thereby customized adaption possible easy)

Additional configuration:

(optional)

Profinet IO Controller

Scope of delivery:

- Mounting kit with grounding terminal
- Technical data sheet



Figure above: View to rear side and connections sides of PC717T-PNC

Figure below: CPU-connections of all Panel-PLC-devices with periphery slots with CPUs type T and with option Profinet IO Controller on slot 1

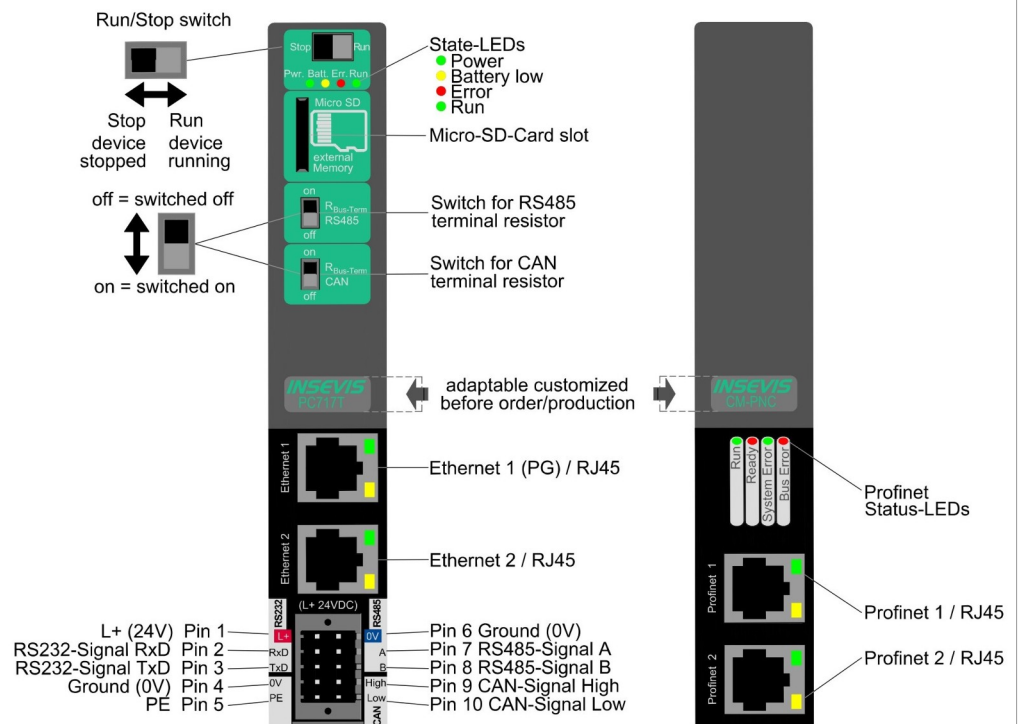

Technical data	
Dimensions W x H x D (mm)	222 x 147 x 95
Cut out W x H (mm)	203 x 126
Weight	ca. 700g
Operating temperature range	-20°C ... +60°C (without condensation)
Storage temperature range	-30°C ... +80°C
IP-protection class front panel	IP65
rear side	IP41
Connection technology	removable connector with 2 bolt flanges (cage clamp technology) for cross section up to max. 1,5mm ²
Load voltage L+	24V DC (11 V ... 30V DC)
Current consumption	200mA ... 1300mA
Power dissipation	4,8W (typ.) ... 31,2W (max. with Profinet and full of periphery)
Start-up current	< 3A
Diagonal of display (inch)	7" (178mm)
Display resolution (pixel)	800x480 Pixel (WVGA)
Display unit	TFT display with 16Bit colours
Operating unit	analog resistive touch screen
Visualization tool unit to reference there	VisuStage PC710T, PC717T
Technical data	
CPU	
CPU-type	CPU-T (PC717T)
Working memory = battery backed load memory	1MB 512 kByte remanent 8MB
Diagnostic buffer	100 entries (all remanent)
Flash internal - for visualization external memory	48 MByte Micro SD, up to max. 8 GByte (not necessary for S7-program, only for archiving)
OB, FC, FB, DB Local data	each 2.048 32kByte (2kByte per block)
Number of in- and outputs	in each case 4.096 Byte (32.769 Bit) addressable
Process image	in each case 4.096 Byte (default set is 128 Byte)
Number of merkerbytes	4.096 (remanence adjustable, default set is 0..15)
Number of taktmerker	8 (1 Merkerbyte)
Number of timer, counter	in each case 512 (each remanence adjustable, default set is 0)
Depth of nesting	up to 16 code blocks
Real-time clock elapsed hour counter	yes (accumulator-backed hardware clock) 1 (32Bit, resolution 1h)
Program language	STEP 7® - AWL, KOP, FUP, S7-SCL, S7-Graph from Siemens
Program system	SIMATIC® Manager from Siemens or products compatible to it
Operating system	compatible to S7-300® from Siemens
Program unit to reference	CPU 315-2DP/PN (6ES7 315-2EH14-0AB0 and firmware V3.1 Siemens)
Serial interfaces (protocols)	COM1: RS 232 (free ASCII) COM2: RS 485 (free ASCII, Modbus-RTU)
Ethernet (protocols)	2x Ethernet: (switch or separated ports): 10/100 MBit with parts of CP343 functionality (RFC1006, TCP, UDP, Modbus-TCP)
CAN (protocols)	CAN-telegrams (Layer 2), compatible to CANopen® master/ slave 10 kBaud ... 1 MBaud
optional interfaces (protocols)	Profinet IO Controller
Onboard periphery	7 slots (optional Profinet uses Slot 1)
Decentral periphery	- INSEVIS- periphery (with automatic configuration via „ConfigStage“) - diverse external periphery families (Modbus RTU/TCP, CAN) - all CANopen® slaves according to DS401 - all Profibus DP-V0-slaves

Cut out in switching cabinet

Dimensions

Cut out
W x H (mm) / 203 x 126
6 holes with D 4,5mm

Wiring outlet

at rear view and
horizontal mounting

PC717T

Wiring outlet
- 45° down

Mounting depth
ca.95mm max.

Drill jig

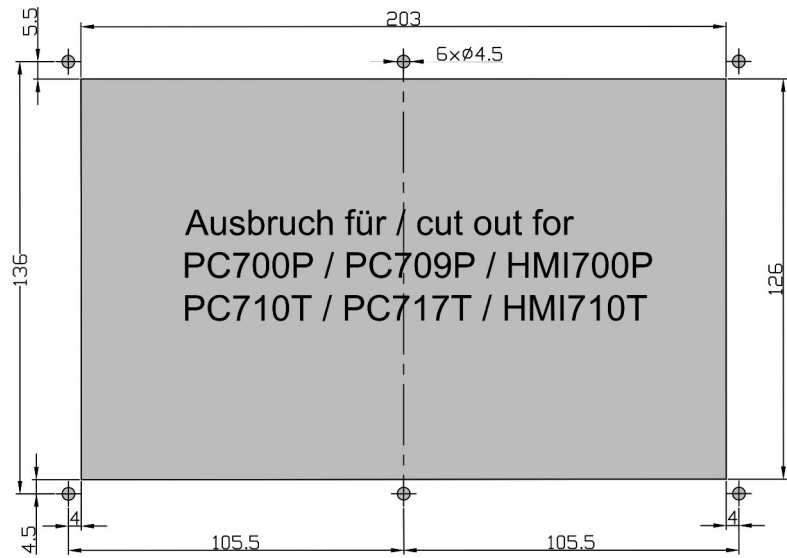

An 1:1 pattern as drill jig is available as PDF at INSEVIS web site for this product
Print it 1:1 and use it for marking the cut out.

Ordering data of devices

Identification	Standard	With Profinet IO Controller
S7-Panel-PLC PC717T	PC717T-0-02	PC717T-PNC-02

Ordering data of accessoires (Peripheral modules to be ordered separately as required)

Identification / Order-No.	Identification / Order-No.
Connector 2x5pin (bolt flanges) / E-CONS10-00	Micro SD-card 2GB (external memory) / E-MSD2-00
Micro SD-card 4GB (external memory) / E-MSD4-00	Micro SD-card 8GB (external memory) / E-MSD8-00

Qualified personnel

All devices described in this manual may only be used, built up and operated together with this documentation. Installation, initiation and operation of these devices might only be done by instructed personnel with certified skills, who can prove their ability to install and initiate electrical and mechanical devices, systems and current circuits in a generally accepted and admitted standard.

Manuals, sample programs

Additional documentation by manuals is available as well sample applications at the download area of www.insevis.com in English language for free download.

Copyright

This and all other documentation and software, supplied or hosted on INSEVIS web sites to download are copyrighted. Any duplicating of these data in any way without express approval by INSEVIS GmbH is not permitted. All property and copy rights of these documentation and software and every copy of it are reserved to INSEVIS GmbH.

Trade Marks

INSEVIS refers that all trade marks of particular companies used in own documentation are reserved trade marks are property of the particular owners and are subjected to common protection of trade marks.

Disclaimer

All technical details in this documentation were created by INSEVIS with highest diligence. Anyhow mistakes could not be excluded, so no responsibility is taken by INSEVIS for the complete correctness of this information. This documentation will reviewed regularly and necessary corrections will be done in next version. With publication of this data all other versions are no longer valid.

Disposal



Do not throw old appliances in the household waste! In the interest of environmental protection, old appliances must be collected separately from unsorted municipal waste. You can find out more about the proper disposal / return of your old appliance at www.insevis.com/disposal.

Attention: The deletion of personal data on the old devices to be disposed of is the responsibility of the end user.

With publication of this information all other versions are no longer valid.