

Product information

S7-Panel-PLC

PC1010T



Image of PC1010T without Profinet (PC1010T-0-03)



Image of PC1010T with Profinet (PC1010T-PNC-02)



(valid from PLC-version HMI1010T-xxx-**02**)

Changes to older versions of this document

- Rev. 01** → **02**: new images, new design line, connectors added, drill jig info added
- Rev. 02** → **03**: changed to CPU-T slim version
- Rev. 03** → **04**: Information for disposal of old equipment

Description

S7-Panel-PLC with

- 10,1" TFT display (1024x600 pixel)
- resistive touch (front protection class IP65)

Standard configuration:

RS232 with

- free ASCII protocol

RS485 with

- free ASCII protocol
- Modbus RTU
- with switchable terminate resistors for RS485

2x Ethernet (as switch or separated) with

- S7-connection (Put/Get)
- Send/ Receive via TCP and UDP,
- Modbus TCP

CAN

- protocol compatible to
 - CANopen®
 - Layer2 communication
- with switchable terminate resistors for RS485

Micro-SD-card slot

- for SD-cards up to 8GByte

Run/Stop switch

State LEDs for

Power, Battery, Error, Run

Inserting stripes

- for Logo and identification (thereby customized adaption possible easy)

Additional configuration:

(optional)

Profinet IO Controller

Scope of delivery:

- Mounting kit with grounding terminal i
- Technical data sheet

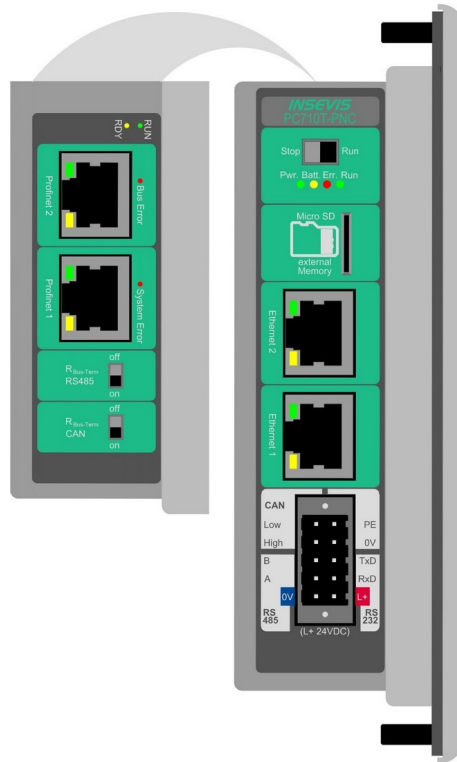
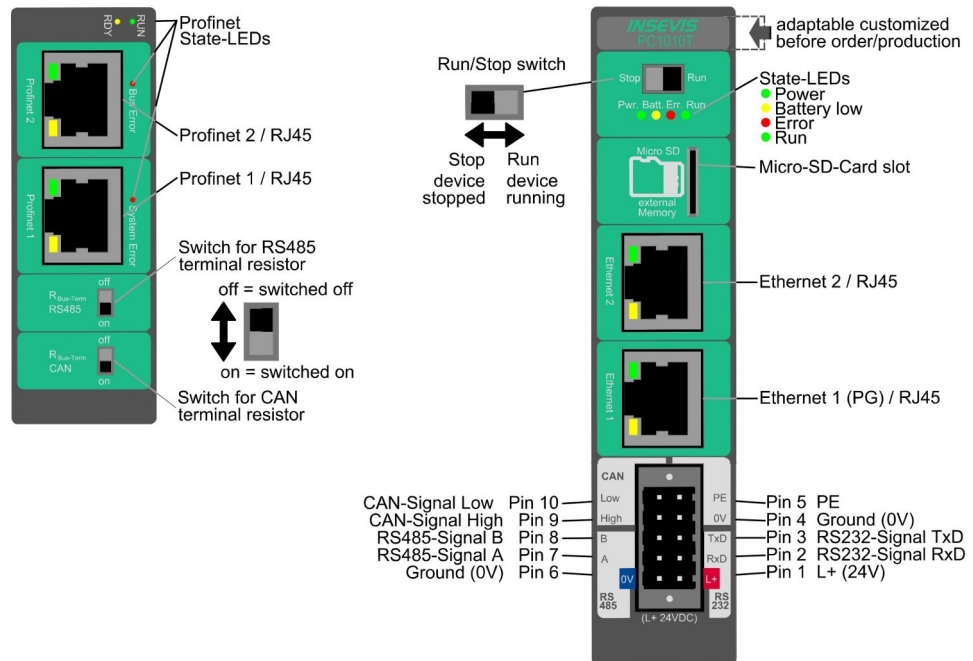

Figure above: View to rear side and connections sides of PC1010T-PNC

Figure below: CPU-connections of all Panel-PLC-basic devices (without periphery slots) with CPUs type T and with option Profinet IO Controller



→ Interfaces are shifted a little bit among each other at the version PC1010T-0-03, but functions and connections are kept similar to the other CPU-T versions (no image, self explanatory)

Technical data	
Dimensions W x H x D (mm) Cut out W x H (mm) Weight	286 x 188 x 53 (48mm mounting depth) 262 x 165,5 ca. 950 g
Operating temperature range Storage temperature range Relative humidity	-20°C ... +60°C (without condensation) -30°C ... +80°C up to 96% (without condensation)
IP-protection class Vibrations	front panel IP65 rear side IP41 Frequency range 2 -100Hz, amplitude 1mm peak < 13,2Hz acceleration 0,7g >13,2Hz
Connection technology	removable connector with 2 bolt flanges (cage clamp technology) for cross section up to max. 1,5mm ²
Load voltage L+	24V DC (11 V ... 30V DC)
Current consumption Power dissipation	350mA ... 500mA 8,5W (typ.) ... 12W (with Profinet)
Start-up current	< 3A
Diagonal of display (inch) Display resolution (pixel)	10,1" (258mm) 1024x600 Pixel (16:9)
Display unit Operating unit	TFT display with 16Bit colours analog resistive touch screen
Visualization tool unit to reference there	VisuStage PC1010T, PC1017T
Technical data	
CPU	
CPU-type	CPU-T (PC1010T)
Working memory = battery backed load memory Diagnostic buffer	1MB 512 kByte remanent 8MB 100 entries (all remanent)
Flash internal - for visualization external memory	48 MByte Micro SD, up to max. 8 GByte (not necessary for S7-program, only for archiving)
OB, FC, FB, DB Lokal data Number of in- and outputs Process image Number of Merkerbytes Number of Taktmerker Number of timer, counter Depth of nesting	each 2.048 32kByte (2kByte per block) in each case 4.096 Byte (32.769 Bit) addressable in each case 4.096 Byte (default set is 128 Byte) 4.096 (remanence adjustable, default set is 0..15) 8 (1 Merkerbyte) in each case 512 (each remanence adjustable, default set is 0) up to 16 code blocks
Real-time clock elapsed hour counter	yes (accumulator-backed hardware clock) 1 (32Bit, resolution 1h)
Program language Program system	STEP 7® - AWL, KOP, FUP, S7-SCL, S7-Graph from Siemens SIMATIC® Manager from Siemens or products compatible to it
Operating system Program unit to reference	compatible to S7-300® from Siemens CPU 315-2DP/PN (6ES7 315-2EH14-0AB0 and firmware V3.1 Siemens)
Serial interfaces (protocols)	COM1: RS 232 (free ASCII) COM2: RS 485 (free ASCII, Modbus-RTU)
Ethernet (protocols)	2x Ethernet: (switch or separated ports): 10/100 MBit with parts of CP343 functionality (RFC1006, TCP, UDP, Modbus-TCP)
CAN (protocols)	CAN-telegrams (Layer 2), compatible to CANopen® master 10 kBaud ... 1 MBaud
optional interface (protocol)	Profinet IO (only at PC1010T-PNC-02) Controller
Onboard periphery	none
Decentral periphery	- INSEVIS- periphery (with automatic configuration via „ConfigStage“) - diverse external periphery families (Modbus RTU/TCP, CAN) - all CANopen® slaves according to DS401 - all Profinet IO devices

