

Product information

S7-Compact-PLC

CC301T



Image of CC301T-0-02

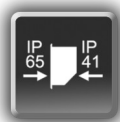

((valid from PLC-version PC431T-0-02))

Changes to older versions of this document

Rev. 01 → 02:

Description

S7-compact-PLC for 35mm DIN-rail with

Standard configuration:

RS232 with
- free ASCII-Protokoll

RS485 with
- free ASCII protocol
- Modbus RTU
- with switchable terminate resistors for RS485

2x Ethernet (as switch or separated) with
- S7-connection (Put/Get)
- Send/ Receive via TCP and UDP,
- Modbus TCP

CAN
- protocol compatible to
- CANopen®
- Layer2 communication
- with switchable terminate resistors for RS485

Micro-SD-card slot
- for SD-cards up to 8GByte

Run/Stop switch

State LEDs for
Power, Battery, Error, Run

Onboard-Periphery
12 digital I/Os
thereof 2 PWM-Outputs
thereof 2 PushPull-Outputs
12 digital Inputs's
thereof 2 Counters 1kHz
thereof 2 Counters 100kHz
3 analog I/O's
((switchable per channel as input/output and for U / I)
3 analog Inputs
(customizable as RTD/ U/ I/ TC/ DMS)

Inserting stripes
- for Logo and identification
(thereby customized adaption possible easy)

Scope of delivery:
- Mounting kit with grounding terminal i
- Technical data sheet

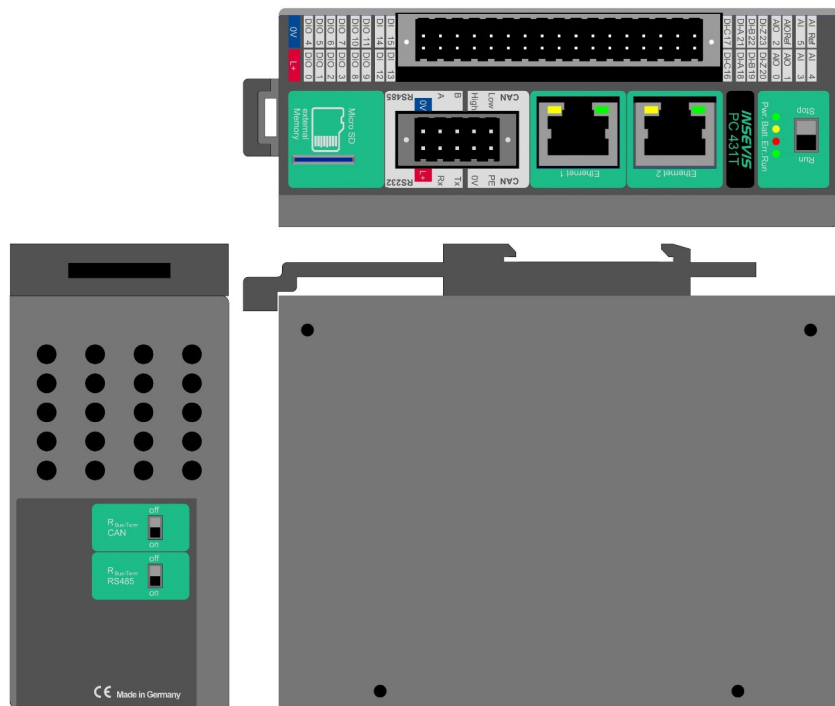

Figure above: View to rear side and connections sides of CC301T (horizontal use)

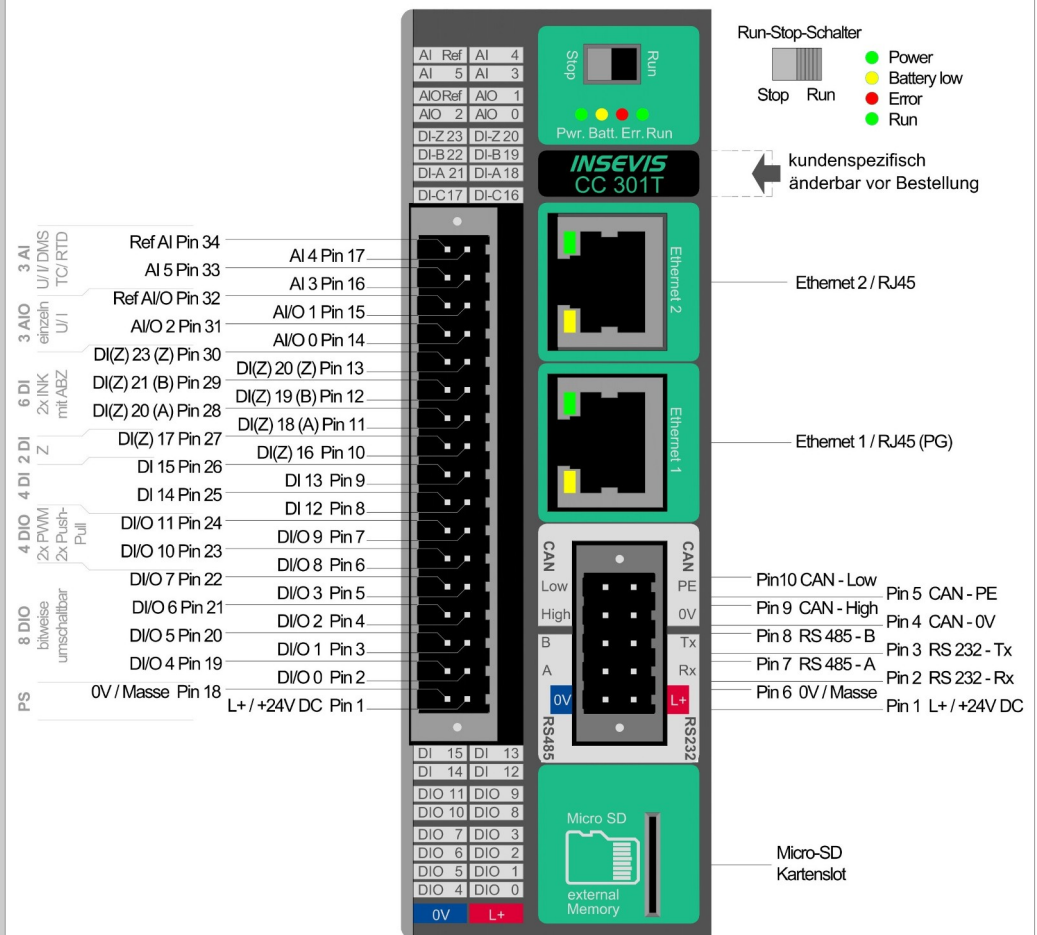
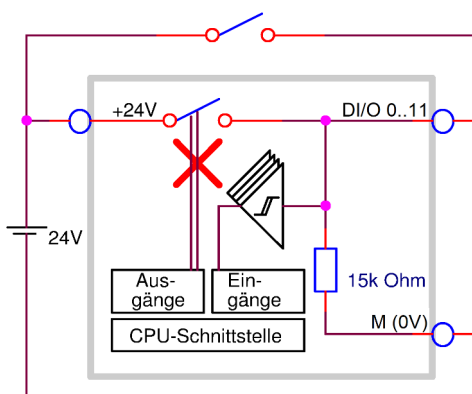

Figure Above: CPU and Periphery connectors of Compact-PLC CC301T

Technical data	
Dimensions W x H x D (mm) mounting, IP-protection class, weight	47 x 116 x 84 on 35mm DIN rail IP41 ca. 250g
Betriebstemperaturbereich Lagertemperaturbereich	20°C ... +60°C (without condensation) -30°C ... +80°C
Connection technology	removable connector 2 bolt flanges (cage clamp technology) for cross section up to max. 1,5mm ²
Load voltage L+	24V DC (11 V ... 30V DC)
Current consumption Power dissipation	200mA 5W (typ.)
Start-up current	< 3A
Technische Daten	
CPU	
CPU-Type	Type T (CC301T)
Working memory = battery backed load memory Diagnostic buffer	1MB 512 kByte remanent 8MB 100 entries (all remanent)
Flash internal - for visualization external memory	48 MByte Micro SD, up to max. 8 GByte (not necessary for S7-program, only for archiving)
OB, FC, FB, DB Lokal data Number of in- and outputs Process image Number of Merkerbytes Number of Taktmerker Number of timer, counter Depth of nesting	each 2.048 32kByte (2kByte per block) in each case 4.096 Byte (32.769 Bit) addressable in each case 4.096 Byte (default set is 128 Byte) 4.096 (remanence adjustable, default set is 0..15) 8 (1 Merkerbyte) in each case 512 (each remanence adjustable, default set is 0) up to 16 code blocks
Real-time clock elapsed hour counter	yes (accumulator-backed hardware clock) 1 (32Bit, resolution 1h)
Program language Program system	STEP 7® - AWL, KOP, FUP, S7-SCL, S7-Graph from Siemens SIMATIC® Manager from Siemens or products compatible to it
Operating system Program unit to reference	compatible to S7-300® from Siemens CPU 315-2DP/PN (6ES7 315-2EH14-0AB0 and firmware V3.1 Siemens)
Serial interfaces (protocols)	COM1: RS 232 (free ASCII) COM2: RS 485 (free ASCII, Modbus-RTU)
Ethernet (protocols)	2x Ethernet: (switch or separated ports): 10/100 MBit with parts of CP343 functionality (RFC1006, TCP, UDP, Modbus-TCP)
CAN (protocols)	CAN-telegrams (Layer 2), compatible to CANopen® master 10 kBaud ... 1 MBaud
Onboard periphery	12 di/O, 12 di (Z), 3 a/I/O (U/ I), 3 aI (U/ I/ RTD/ TC/ DMS)
Decentral periphery	- INSEVIS- periphery (with automatic configuration via „ConfigStage“) - diverse external periphery families (Modbus RTU/TCP, CAN) - all CANopen® slaves according to DS401 - all Profinet IO devices

Technical data		digital Inputs/Outputs	
Load voltage L+ Current consumption Power loss	10 V ... 30 V DC 10 mA (without load) internally limited	Cable length - unshielded (max.) - shielded (max.)	30 m 100 m
Digital inputs/outputs Diagnostic LEDs	8 outputs (each with read-back input) none	Outputs: Switch-on delay Switch-off delay Inputs: Switch-on delay Switch-off delay	50 µs (type.) 30 µs (typ., without load) 1,5 ms 4,5 ms
Digital inputs / Digital push-pull outputs	2x2 push-pull outputs (can be switched off in pairs) (each with read-back input)	Function of the push-pull outputs	output PWM (0..100%) PWM + direction bit (0 .. +/- 100%)
Output current for signal 0 for signal 1 Input current for signal 1	0,5 mA (max.) 0,5 A (max. up to 60°C) 1 mA (type)	Max. switching frequency of the outputs	100 Hz (with resistive load)
Signal level of the outputs for signal 0 for signal 1 Input voltage for signal 0 for signal 1	1,0 V at 500 Ω (max.) L+ - 1,0 V at 0,5 A load (min.) 0V ... +5 V +10,5V ... +30 V	Max. switching frequency of the push/pull PWM outputs	50 kHz (with resistive load)
Function slower counter	2 up counters 16 bit optionally as counter value or frequency [Hz]	Function fast counters	2 counters 16 bit Incremental encoder 4-fold or up-counter Optionally with zero-track reference function
max. frequency slow counter	1 kHz	max. frequency at input pins high-speed counters	100 kHz
Open-circuit monitoring, fault diagnosis Potential isolation to the PLC	no no	Total current	2 A (max. up to 60°C)

Block diagrams digital inputs/outputs



Block diagram of the DIOs only as input for 2-wire encoders

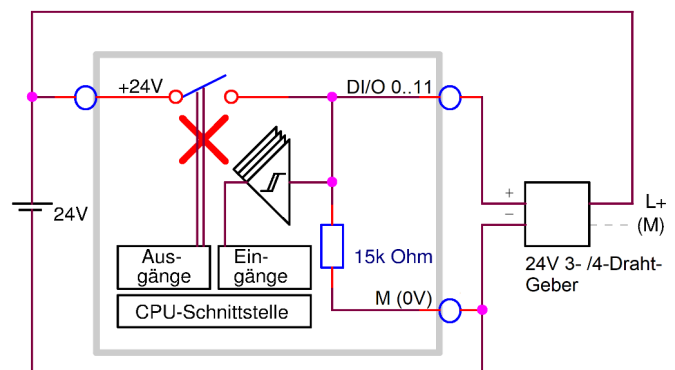

Block diagram of the DIOs for 3-/4-wire encoders

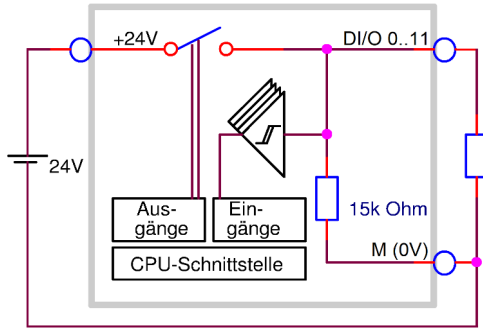

Block diagram of the DI/Os as read-back output

Input address	
Digital :	Start: 0, End: 15
Analog :	Start: 128, End: 139
Output address	
Digital :	Start: 0, End: 7
Analog :	Start: 128, End: 133
Channel 0: Digital input and output	
	Input address Output address
	Disable the output
Channel 0.0	0.0 <input type="checkbox"/> 0.0
Channel 0.1	0.1 <input type="checkbox"/> 0.1
Channel 0.2	0.2 <input type="checkbox"/> 0.2
Channel 0.3	0.3 <input type="checkbox"/> 0.3
Channel 0.4	0.4 <input type="checkbox"/> 0.4
Channel 0.5	0.5 <input type="checkbox"/> 0.5
Channel 0.6	0.6 <input type="checkbox"/> 0.6
Channel 0.7	0.7 <input type="checkbox"/> 0.7

Configuration block start/end addresses (in bytes) and I/O assignment in the ConfigStage

Configuration of the PWM outputs

Push-pull outputs or PWM (setting via ConfigStage)

Channel 1.0/1.1 and 1.2/1.3 in pairs

Configuration "Input"

→ both outputs deactivated

Configuration "Input/Output"

→ 2 read-back outputs
(active high AND low switching !)

Configuration "PWM uni"

→ Channel 1.0 or 1.2 deactivated as bit
Set value of the PWM duty cycle in the specified output word,
Specification of the frequency constant
→ Channel 1.1 or 1.3 as output (can be read back)

Configuration „PWM bidir“

→ Channel 1.0 or 1.2 as uni, but setpoint with sign
→ Channel 1.1 or 1.3 as direction bit (= sign)

Channel 1: Digital input and output or PWM output

	Mode	Input address	Output address	Duty cycle Output address	Frequency [Hz]
Channel 1.0	Input	1.0			
Channel 1.1	Input	1.1			
Channel 1.2	PWM bidir			6	500
Channel 1.3	Input				
Channel 1.4	Input/Output	1.4			
Channel 1.5	Input	1.5			
Channel 1.6	Input	1.6			
Channel 1.7	Input	1.7			

Configuration of the counter inputs

Slow counters

(setting via ConfigStage)

Configuration "Input"

→ Channel 2.0 or 2.1 are normal inputs,
Counter is switched off

Configuration "counting up"

→ On channel 2.0 or 2.1, rising edges are counted

Address of the counter word and the reset bit are displayed (input bit switched off)

"Frequency measurement" configuration

→ The frequency [Hz] is output instead of the counter value

Channel 2: Digital input or Low/High speed counter

	Mode	Input address	Counter word input address	Reset bit output address	Enable bit output address
Channel 2.0	Counter up		4	2.0	
Channel 2.1	Input	2.1			
Channel 2.2 (A)	Frequency measure	2.2			

**Fast counters
(setting via ConfigStage)**

Configuration „Input“

→ Channel 2.2 - 2.4 resp. 2.5 - 2.7 are normal Inputs,
Counter is switched off

Configuration "counting up"

→ Rising edges are counted on channel 2.2 or 2.5,
→ the other signals (B and Z) are inputs

Configuration "counting up/down"

→ rising edges are counted on channel 2.2 buw 2.5 and
→ Channel 2.3 or 2.6 serves as a direction bit (0=backwards, 1=forwards)
→ Z is input

Configuration "Encoder x4"

→ Channel 2.2/2.3 or 2.5/2.6 form an encoder input with quadruple evaluation
→ Z is input

Configuration "counting up/down zero" "Encoder x4 zero"

→ In addition, the Z input can be activated via the "enable reference" bit:
On a rising edge at the Z bit, the counter is reset to 0 and the enable reference bit is deleted.
Notes on using the counter inputs

Channel 2: Digital input or Low/High speed counter

	Mode	Input address	Counter word input address	Reset bit output address	Enable bit output address
Channel 2.0	Counter up		4	2.0	
Channel 2.1	Input	2.1			
Channel 2.2 (A)	Counter up	2.2			
	Frequency measure				

Notes on using the counter inputs

- Counters can only be set (and held) to zero by setting the reset bit (static)
- the configuration cannot be changed at runtime under Step7:
- all addresses are specified as an offset in relation to the configured start address

Technical data	analog Inputs/Outputs U/I		
Load voltage L+	- (internal supply)	Cable length - unshielded (max.) - shielded (max.)	30 m 100m
Analogue inputs Input ranges	3 (alternatively configurable to outputs via software) 0...20 mA, 4...20 mA, +/- 20mA 0...10 V	Permissible voltage between inputs and A-GND (max.)	-1 V ... + 24 V DC
Diagnostic LEDs	none	Error message if range is exceeded	Parameterizable diagnostic and limit value alarms on request
Number format	9400 ... 6C00 (hexadecimal) for measuring range +/- 20mA otherwise 0000 ... 6C00 (hexadecimal)	Wire break monitoring	by exceeding or falling below the measuring range (for 4..20 mA)
Overload range	20 mA ... 22 mA 10V ... 11,3 V	Signal transmitter connection type	unbalanced to A-GND (single ended)
Input resistance	0Ω (typ.) for measuring range current 1MΩ (typ.) for voltage measuring range	Measuring principle/ Conversion principle	successive approximation 12 Bit
Abtastzykluszeit = IntegrationszeitSampling cycle time = Integration time	parameterizable 1ms ... 35767 ms default: 100 ms (= mains frequency filter 50Hz and 60Hz)	Accuracy (related to measuring range)	< 1%
Analogue outputs Output ranges	3 (alternatively to inputs configurable via software) 0(4)...20mA , 0...10V	Number format	0000 ... 6C00 (hexadecimal)
Output resolution	12 Bit	Short-circuit protection	yes
Diagnostic LEDs	none	Overdrive range	20 ... 23 mA 10 ... 11,3 Vsettling timeSettling time:
Settling time:	Time constant t (typ) 1,5 ms	Short-circuit current (typ.)	20 mA (at 10V) 32 mA (at mA)
Load resistor/ load resistor to A-GND	mA: 500 Ω (max.) V: 1 kΩ (min.)	Accuracy (related to measuring range)	< 1%

Block diagrams analog inputs/outputs U/I

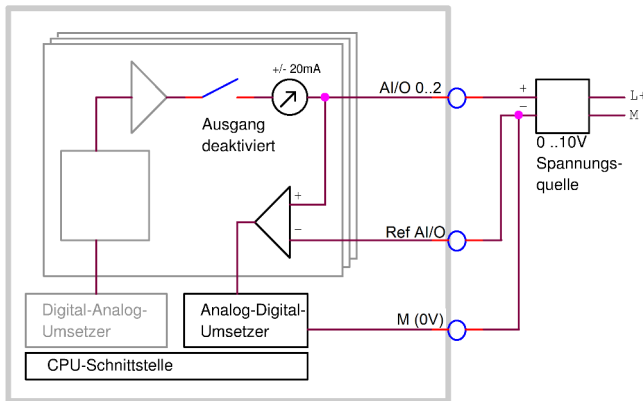

Block diagram of the analog inputs for 0 ... 10 V

Channel 3...5: Analog Input and Output

Integration time [ms]:

Channel	Mode	Type	Address
Channel 3	Input	0...10V	128
Channel 4	Output	0...10V	130
Channel 5	Input	0...10V	132

Dropdown menu for Channel 5 Type: 0...10V, 0...20mA (2-wire), 4...20mA (2-wire), 4...20mA (4-wire), +/- 20mA (4-wire)

Configuration block addresses (in bytes) and measuring range configuration Analogue I/O in the ConfigStage

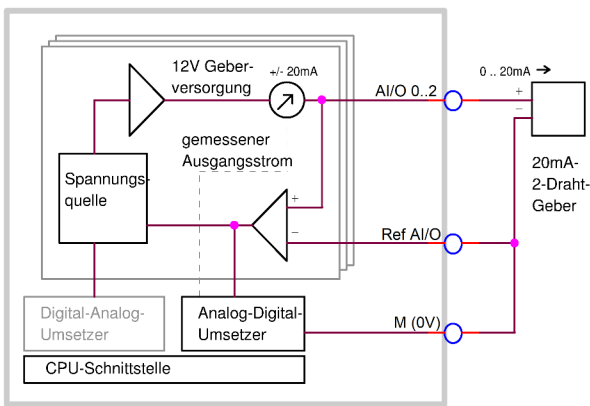

Block diagram of the analogue inputs for 20 mA with 2-wire encoder

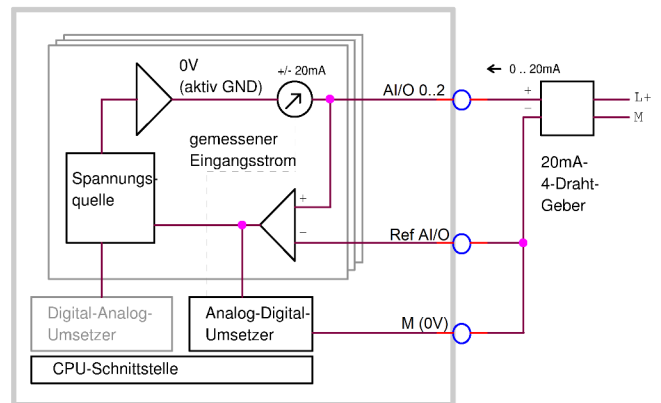

Block diagram of the analogue inputs for 20 mA with 3/4-wire encoder

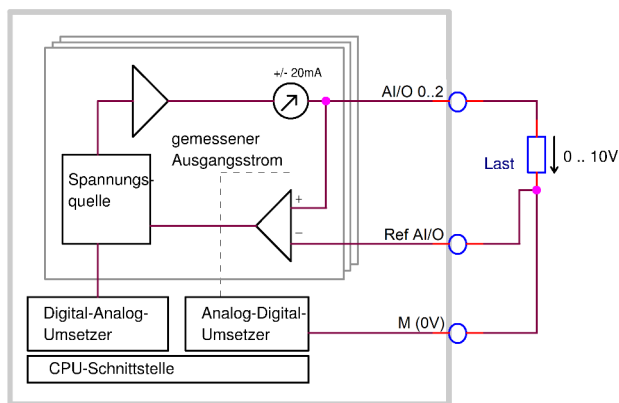

Block diagram of the analogue outputs for 10 V

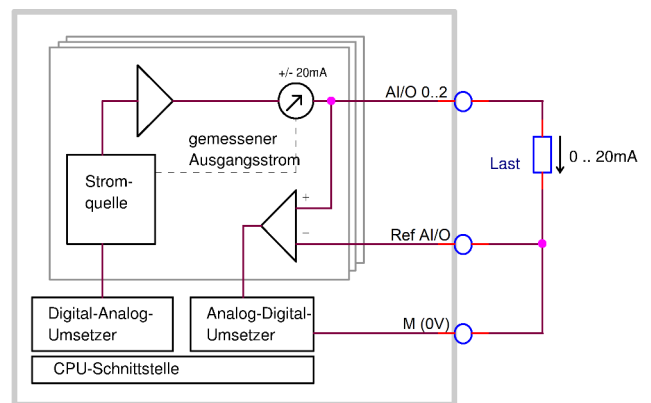

Block diagram of the analogue outputs for 20 mA

Technical data	Analog inputs U//RTD/TC/SG		
Load voltage L+	- (internal supply)	Cable length - unshielded (max.) - shielded (max.)	30 m 100m
Input ranges	0...20 mA, 4...20 mA, 0..10 V, DMS, PT100, PT1000, 2 kOhm, TC possible combinations: - 3x 20 mA or 10 V - 1x DMS - 3x PT100/PT1000/R (2 wire) - 1x PT100/PT1000/R (3 wire) + 1x PT100/PT1000/R (2 wire) - 2x ThermoCouples , 1x PT100	Permissible voltage between inputs and A-GND (max.)	-1 V ... + 24 V DC
Diagnostic LEDs	none	Error message if range is exceeded	Parameterizable diagnostic and limit value alarms on request
Number formats: Measuring range 20mA /10V: PT100 / TC	0 ... 6C00 (hexadecimal) 1/10 °C, 1/100 °C	Wire break monitoring	due to overrange or underrange
Overdrive range	20 mA ... 22 mA 10V ... 11,3 V	Connection type of the signal transmitter Measuring ranges mA, V: otherwise:	unbalanced (single ended) against 0V potential-free (floating)
Input resistance	70Ω (typ.) for measuring range mA 1MΩ (typ.) otherwise	Measuring principle/ Conversion principle Resolution	Sigma Delta 16 Bit
Sampling cycle time = Integration time	parameterizable default: 100 ms depending on the measuring range	Accuracy (related to measuring range)	< 1%
Internal resistance strain gauges	1kOhm		

Blockschaltbilder analoge Eingänge U//RTD/TC

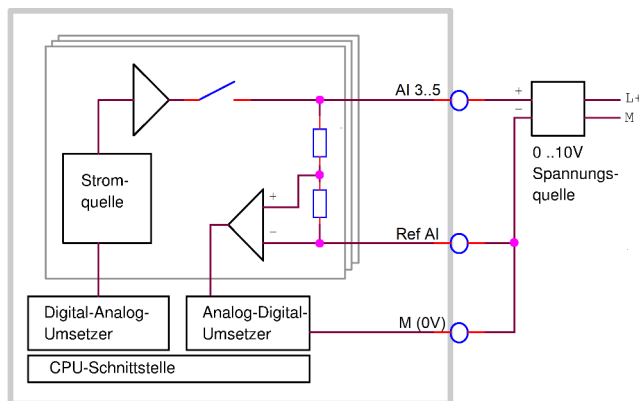

Block diagram of the analog inputs for 0 ... 10 V

Channel 6...8: Analog Input

Integration time [ms]:

Mode: Voltage / Current (0..10V, 0..20mA, 4..20mA)
 Temperature (PT100, PT1000, TC)

Channel	Type	Address
Channel 6	0..10V	134
Channel 7	0..10V	136
Channel 8	0..20mA (4-wire) 4..20mA (4-wire) strain gauge	138

Configuration block addresses (in bytes) and measuring range configuration in the ConfigStage Voltage/current mode

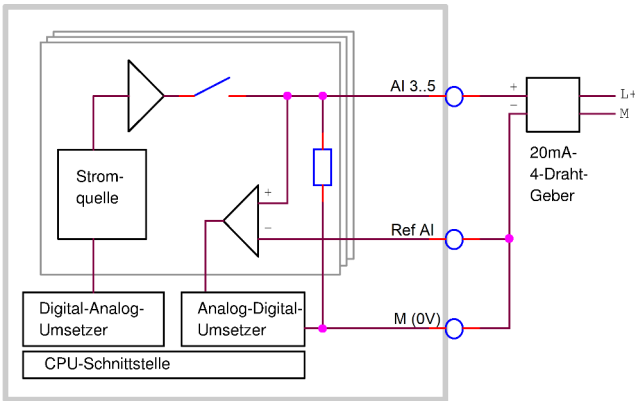

Block diagram of the analog inputs for 20 mA with 3/4 wire encoder

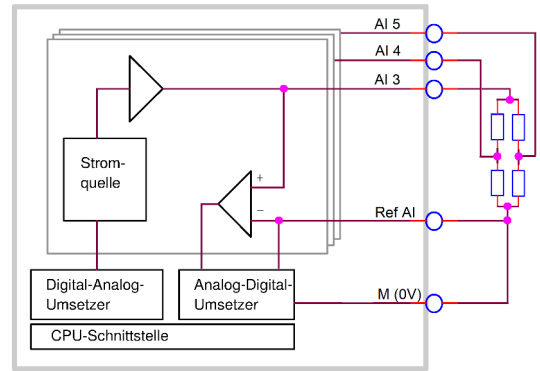

Block diagram of the analog inputs for strain gages (strain gauge)

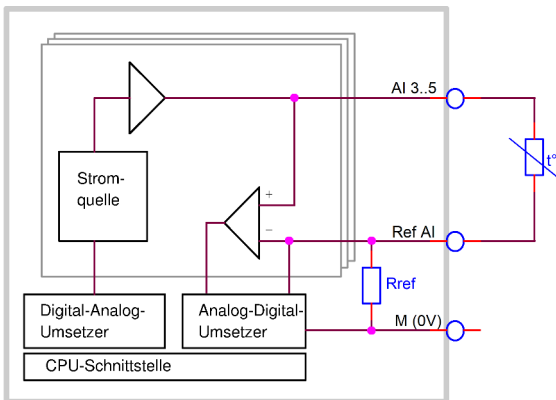

Block diagram of the analog inputs for PT100/PT1000/R 2-wire

Channel 6...8: Analog Input

Integration time [ms]: 100

Mode: Voltage / Current (0..10V, 0..20mA, 4..20mA) Temperature (PT100, PT1000, TC)

Channel	Type	Address
Channel 6	PT100 (2-wire) climatic	134
Channel 7	PT100 (2-wire) climatic	136
Channel 8	PT100 (2-wire) standard	138

Configuration block addresses (in bytes) and measuring range configuration Analog Input in the ConfigStage Mode temperature

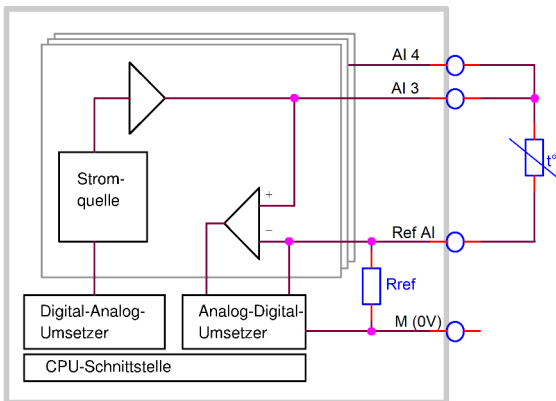

Block diagram of the analog inputs for PT100/PT1000/R 3-Wire

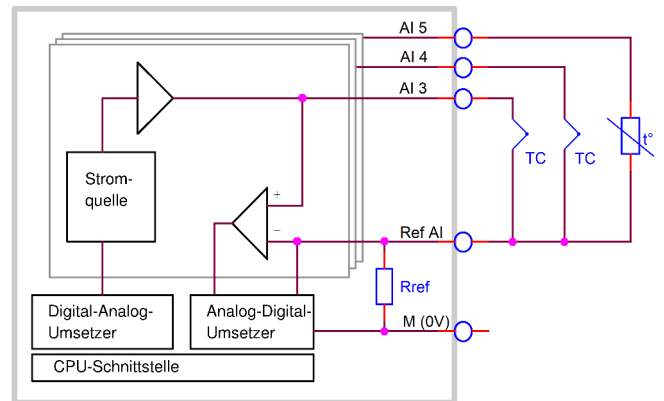

Block diagram of the analog inputs for thermocouples

Assignment of the process image:

Assignment of the process image: Digital inputs The module occupies 16 bytes in the process image (from the configured start address).			
Offset	I/O	Function	Description
0..2	I	Input DI0.0..DI2.7	Input bits (possibly blocked - depending on configuration)
3	I	reserved	
4,5	I	Slow counter 0	Counter word (16-bit high-endian), measuring range depending on configuration
6,7	I	Slow counter 1	Counter word (16-bit high-endian), measuring range depending on configuration
8..11	I	Fast counter 0	Counter word (32-bit high-endian), measuring range depending on configuration
12..15	I	Fast counter 1	Counter word (32-bit high-endian), measuring range depending on configuration

Assignment of the process image: Digital outputs The module occupies 8 bytes in the process image (from the configured start address).			
Offset	I/O	Function	Description
0	O	Output DO0..DO7	Standard-PLC outputs
1	O	Output DO8..DO11	4 push/pull outputs (4 bits unused)
2	O	Resetbits slow counter	.0 Reset Counter 0, .1 Reset Counter1
3	O	Reset-/Controlbits fast counter	.0 Reset Counter 0, .1 Reset Counter1 .2 EnableRef Counter 0, .3 EnableRef Counter1
4,5	O	PWM 0 target value	(16 Bit high-endian)
6,7	O	PWM 1 target value	(16 Bit high-endian)

Assignment of the process image: Analog inputs The module occupies 6 input words in the process image (from the configured start address).			
Offset	I/O	Function	Description
0,2,4	I	Input AI0..AI2	Measurement range depending on configuration
6,8,10	I	Input AI3..AI5	Measurement range depending on configuration

Assignment of the process image: Analog outputs The module occupies (from configured start address) 3 output words in the process image.			
Offset	I/O	Function	Description
0,2,4	O	Output AO0..AO2	Measurement range depending on configuration

BOordering data of devices

Identification	Standard
S7-Compact-PLC CC301T	CC301T-0-02

Ordering data of accessoires

Identification / Order-No.	Identification / Order-No.
Connector 2x5pin (bolt flanges) / E-CONS10-00	Micro SD-card 2GB (external memory) / E-MSD2-00
Connector 2x17polig (Locking lever) / E-CON34-00	Micro SD-card 4GB (external memory) / E-MSD4-00
Connector 2x17polig (bolt flanges) / E-CONS34-00	Micro SD-card 8GB (external memory) / E-MSD8-00

Qualified personnel

All devices described in this manual may only be used, built up and operated together with this documentation. Installation, initiation and operation of these devices might only be done by instructed personnel with certified skills, who can prove their ability to install and initiate electrical and mechanical devices, systems and current circuits in a generally accepted and admitted standard.

Manuals, sample programs

Additional documentation by manuals is available as well sample applications at the download area of www.insevis.com in English language for free download.

Copyright

This and all other documentation and software, supplied or hosted on INSEVIS web sites to download are copyrighted. Any duplicating of these data in any way without express approval by INSEVIS GmbH is not permitted. All property and copy rights of these documentation and software and every copy of it are reserved to INSEVIS GmbH.

Trade Marks

INSEVIS refers that all trade marks of particular companies used in own documentation are reserved trade marks are property of the particular owners and are subjected to common protection of trade marks.

Disclaimer

All technical details in this documentation were created by INSEVIS with highest diligence. Anyhow mistakes could not be excluded, so no responsibility is taken by INSEVIS for the complete correctness of this information. This documentation will reviewed regularly and necessary corrections will be done in next version. With publication of this data all other versions are no longer valid.

Disposal



Do not throw old appliances in the household waste! In the interest of environmental protection, old appliances must be collected separately from unsorted municipal waste. You can find out more about the proper disposal / return of your old appliance at www.insevis.com/disposal.

Attention: The deletion of personal data on the old devices to be disposed of is the responsibility of the end user.

With publication of this information all other versions are no longer valid.